

HMP 3021 & 3025 PONTOON LIFT

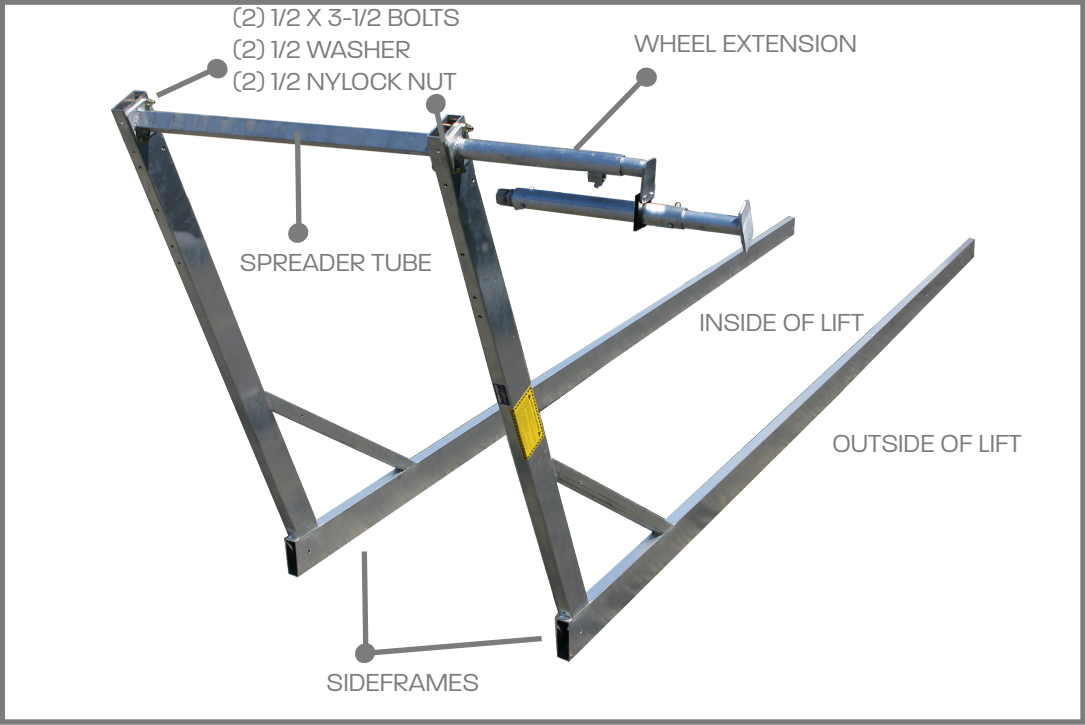

PLEASE READ THROUGH ALL OF THE INSTRUCTIONS BEFORE BEGINNING. DETERMINE WHICH SIDE YOU WOULD LIKE THE WINCH ON PRIOR TO ASSEMBLY. IF POSSIBLE, ASSEMBLE THE LIFT ON A FLAT, LEVEL SURFACE. LIFT MUST BE LEVEL WHEN IT IS INSTALLED FOR THE LIFT TO OPERATE PROPERLY. EXTENSION LEGS ARE AVAILABLE FROM YOUR AUTHORIZED HARBOR MASTER DEALER. GREASE THE ROLLERS AFTER ASSEMBLY AND THROUGHOUT THE SEASON FOR BEST USE.

STEP 1:

BOLT SIDEFAMES TOGETHER WITH THE SPREADER TUBE USING (2) 1/2" X 3-1/2" BOLTS PER SIDE WITH WASHERS ON THE OUTSIDE OF THE LIFT & 1/2" NYLOCK NUT ON THE INSIDE OF THE LIFT. BOLT THE WHEEL EXTENSION ON THE SIDE OF THE LIFT YOU WANT THE WHEEL ON.



SPREADER TUBE



PONTOON WHEEL EXTENSION

STEP 2:

BOLT THE V-FRAMES OR H-FRAME TO THE SIDEFAMES. (SEE DIAGRAM BELOW.)



FROM OUTSIDE OF LIFT TO INSIDE:
1/2 X 5-1/2 BOLT, 1/2 STEEL WASHER, 1/2 NYLON WASHER BETWEEN, 1/2 STEEL WASHER, & 1/2 NYLOCK NUT.

STEP 3:

BOLT THE PULLEY SIDE ASSEMBLY TO FRONT V-FRAME OR H-FRAME.

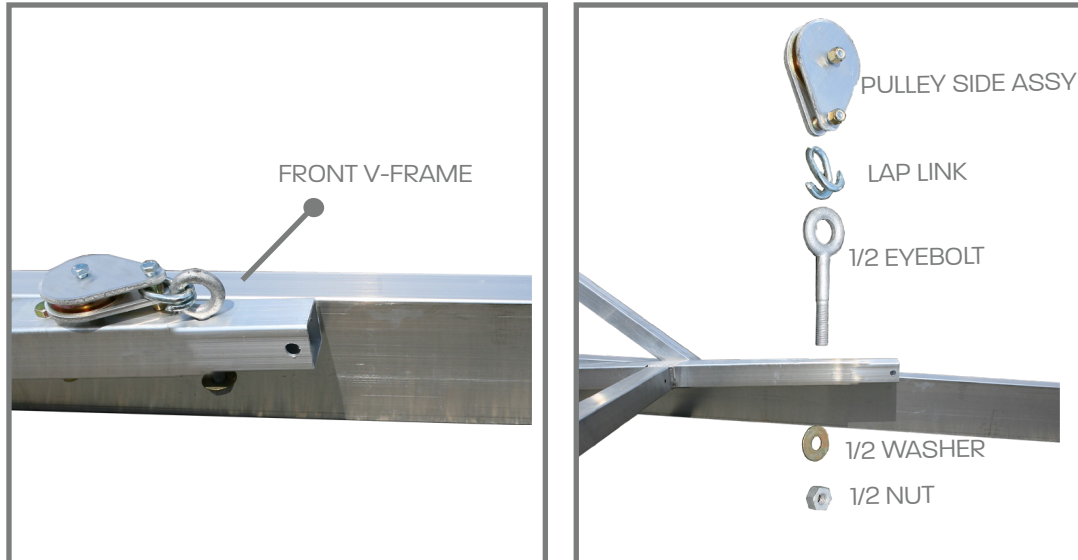

STEP 4:

BOLT TOP RAILS TO V-FRAMES OR H-FRAMES USING 1/2 X 3-1/2 BOLT & 1/2 NYLOCK NUT.



STEP 5:

THREAD THE WHEEL NUT ONTO THE WINCH. THREAD THE BOLT, SPACER AND SPRING INTO THE WINCH SHAFT. BOLT THE WINCH TO THE SIDEFAME.

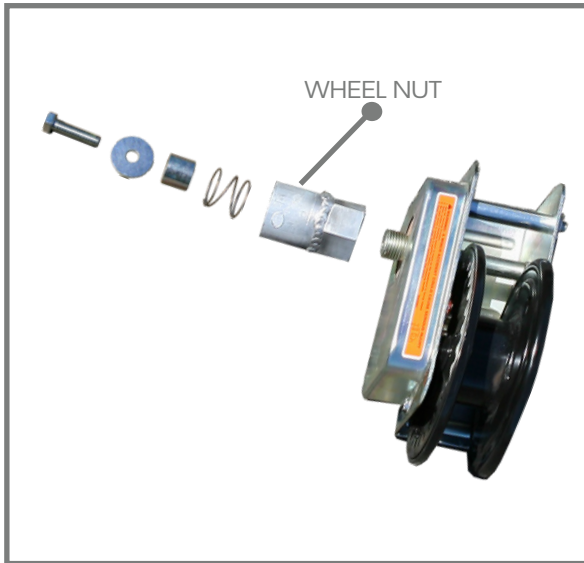

WINCH SETUP



TIGHTEN THE BOLT PARTS DOWN ON THE WINCH.



(2) 3/8 X 5-1/2 BOLT WITH WASHERS & NUT ON THE BACK TO HOLD THE WINCH ON.

STEP 6:

BOLT THE EXTENSION TUBE ON THE WHEEL NUT. BOLT THE WHEEL TO THE WHEEL EXTENSION.

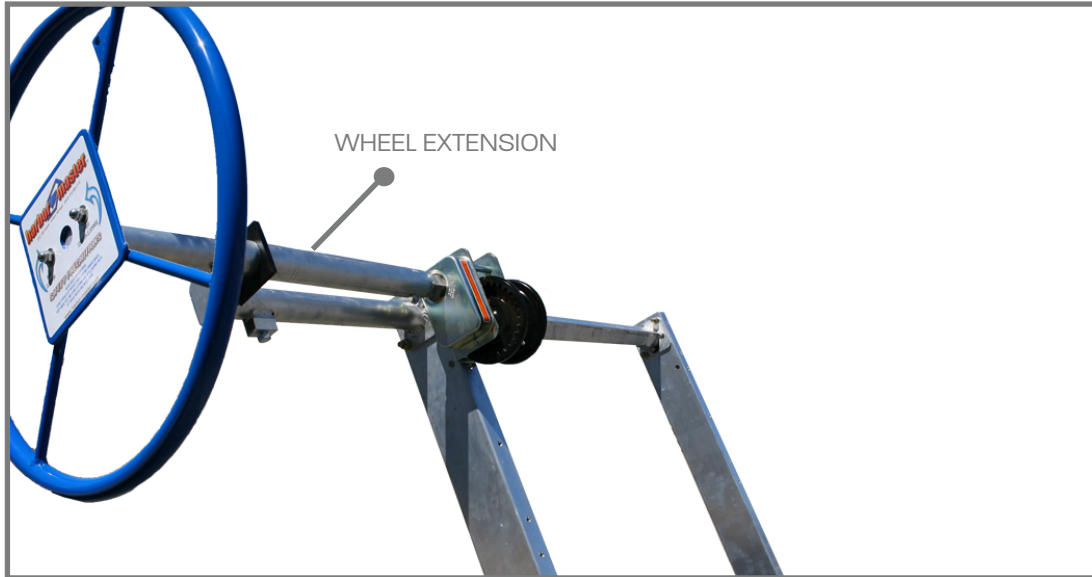

STEP 7:

INSTALL THE PULLEYS TO THE SIDEFAMES WITH U-BOLTS. THE TOP PULLEY BOLTS ON UNDER THE WINCH.

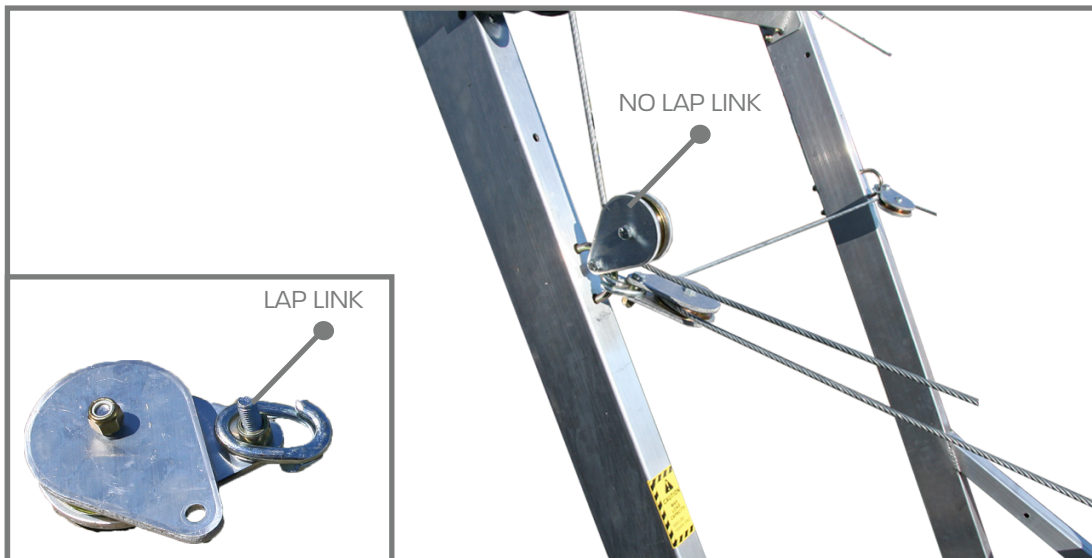

THE TOP PULLEY DOESN'T USE A LAP LINK. USE 7/16 X 6-1/2 U-BOLTS WITH LAP LINKS. USE WASHERS ON THE BACK OF THE UBOLTS W/ NYLOCK NUTS.

STEP 8:

PLACE THE LOOP OF CABLE BEHIND THE WASHER OF THE TOP BOLT OPPOSITE OF THE WINCH. BOLT THE SPINNER KNOB TO THE WHEEL.

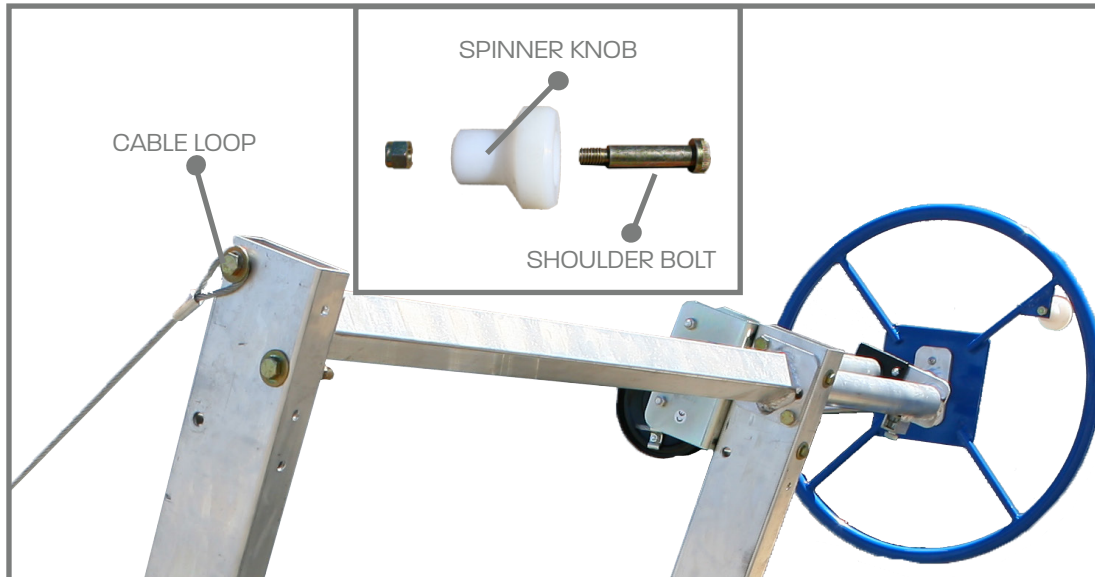

STEP 9:

RUN THE CABLE THROUGH THE PULLEYS AS SHOWN. THEN, RUN THE CABLE INTO THE WINCH AND FASTEN AS INDICATED IN THE WINCH INSTRUCTIONS.

